

Introduction

The Levolux range of internal roller blinds has been enhanced with the introduction of the new Levolux 760SX range of chain operated roller blinds and is ideally suited for use in offices, public buildings, hospitals, schools and applications where glare control is of importance.

The Levolux 760SX provides designers with a robust, heavy duty roller system offering a reliable, functional solution to help glare control reduce solar heat gain and provide light control solutions.

Features & Benefits

Ease of use - the large drive sprocket produces more leverage, making even the largest of blinds light and easy to operate.

Ultimate control - a choice of control mechanisms are available. The Levolux 760SX control is via a continuous stainless steel bead chain with standard, hi-lift and a multi-stop controlled descent option.

Technically reliable - the Levolux 760SX incorporates the latest designs to allow smooth, trouble free operation with minimal maintenance.

The Levolux 760SX is also available in a motorised option with the same parameters as the manual version. Dual blinds are also available.

The Range

Levolux 760SX Roller Blind - a robust, heavy duty, friction roller system with spring brake clutch mechanism that can be raised and lowered to any position by a smooth action continuous stainless steel bead chain mechanism.

Levolux 760SX Hi-Lift Roller Blind - the hi-lift roller system has been developed to operate blinds larger than those capable of being controlled as a standard 760SX operation. The hi-lift has all the features and benefits of the standard blind but incorporates a lift assist mechanism within the operating end of the blind to reduce substantially the amount of effort required to lift and lower a large fabric blind. There is no visual difference between the hi-lift and the standard blind.

Multi-Stop Controlled Descent Option - once again, this option incorporates all the features and benefits of the standard 760SX blind. This blind has been developed to limit the positions at which the blind can be stopped by use of stops on the continuous stainless steel bead chain to ensure a uniformity of look externally. When the blind is not locked at a stop position the blind will automatically default to a lowered position. To achieve this in a safe manner, the blind also incorporates a centrifugal decelerator within the operating mechanism to control the descent of the fabric cover and a unique tensioning mechanism.

System Construction

All components are subject to rigid quality control standards and are designed to produce a high performance, robust product with an aesthetically pleasing finish. The main components are:

- Brackets • Roller barrel • Fabrics
- Bottom bar • Control mechanism • Fascias

Brackets - the slim universal brackets for top or face fix are manufactured from polyester powder coated steel with glass fibre reinforced nylon moulded bodies that control the operating mechanism. The idle end bracket incorporates a unique device to adjust the level of the roller tube assisting installation. The bracket is designed so that extruded aluminium fascias can be securely clipped on without the need to drill holes for the operating chain. Bespoke brackets can be made available.

Roller barrel - two sizes of extruded aluminium barrels are available; 45mm and 50mm. These can be colour coordinated.

Fabrics - for general use to control glare and light a wide range of fabric types are available including fibreglass, trevira, opaque, cotton and polyester. Fabrics are flame retardant, an essential factor to comply with building regulations. For high performance glare and solar heat gain reduction together with outward visibility, a wide range of woven fabrics are available including PVC and hallogen free fabric. The fabrics are attached to the roller barrel by a patented method to allow easy removal and replacement of fabrics without removing the roller from its operating position. The slim brackets produce minimum gaps between the fabrics.

Bottom bar - various types of exposed or covered extruded aluminium or timber bottom bars are available to suit individual project requirements. The same patented method of attaching the fabric to the roller tube can be used on some of these options.

Control mechanism - the Levolux 760SX range of blinds are all operated by 'qualified', continuous, stainless steel bead chain to ensure that even the largest blinds operate smoothly and without juddering.

Fascias - crisp, extruded aluminium fascias clip securely on single or continuous runs of brackets to give a clean, sharp appearance.

3 Year Warranty

All Levolux systems are made of a high grade materials to exacting specification. This enables us to offer a guarantee providing free of charge replacement parts should any system prove defective within 3 years of installation. This guarantee is conditional on manufacturer's recommended fitting, operating and maintenance instructions having been followed.



Options of operating chain positions

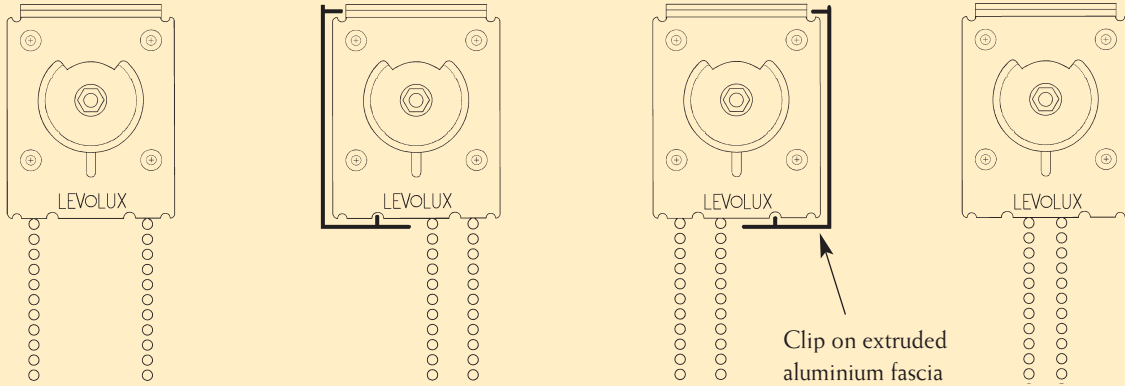

Operating End

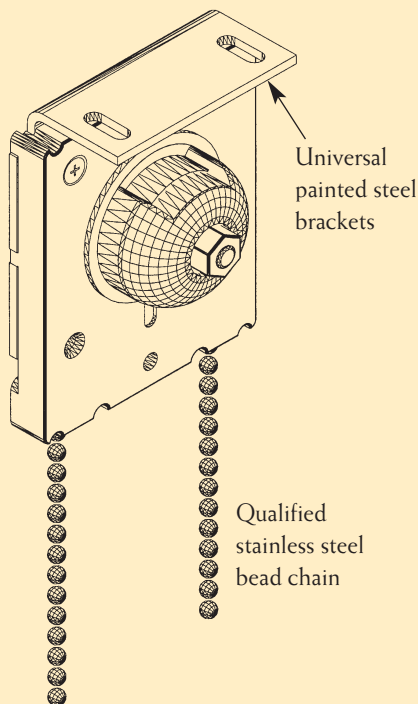

Bottom bar options

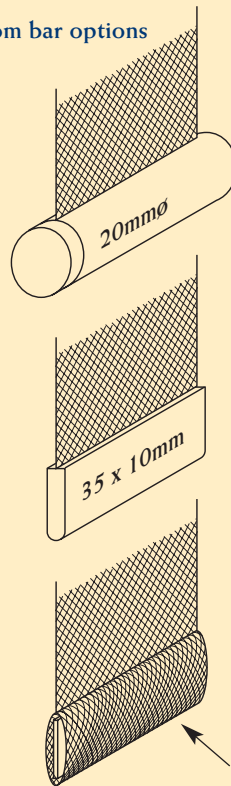

'Pin' End

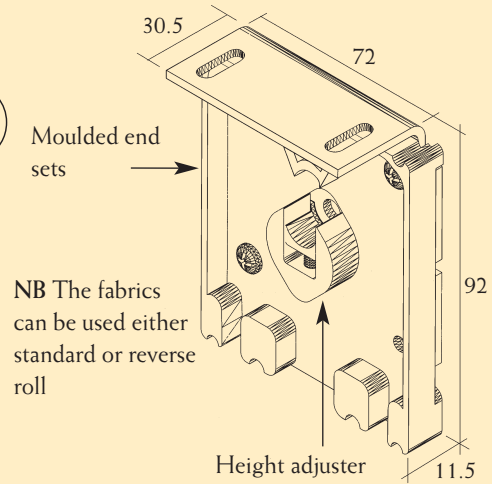

Fabric gap operating end - 15mm
Fabric gap idle end - 17mm

System parameters

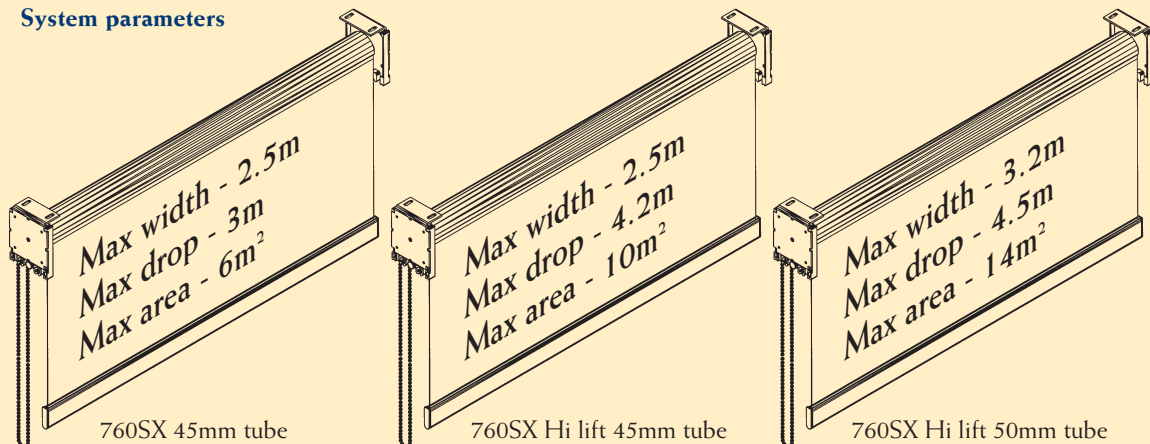

Max sizes shown are indicative & subject to fabric weights per square metre.
Patents pending in USA and UK, application numbers 10/887091 and 0322955.6 respectively



Side Guides

For blinds on moving applications such as doors, tilting windows or draughty situations, side guides can be fitted. Two standard types are available, perlon or steel cables, or extruded aluminium sections.

Most components are supplied in standard finish but can also be anodised or polyester powder coated to your requirements.

Optional Extras

Hold down brackets, chain locks, fascias, end covers and a variety of bottom bars are also available.

Typical side guiding details

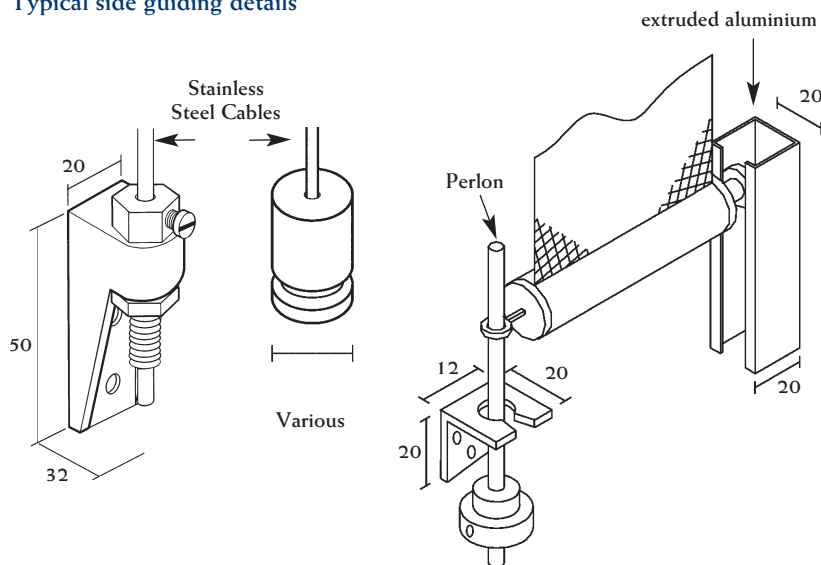

Specification

Manufacturer and reference: Levolux 760SX Standard/Hi-Lift/Multi-Stop Controlled Descent Roller Blind supplied and installed by Levolux

Description: Internal manual gravity roller blind operated by continuous ball chain. Fabric secured to extruded anodised aluminium roller barrel with nylon fabric spine allowing for easy removal and replacement of fabric cover without removing blind hardware.

Material: Heavy duty spring friction clutch/Hi-lift assist mechanism.

Qualified stainless steel ball chain.

Universal 71 x 92mm painted 2.5mm steel chassis with Nylon 66 moulded bracket (in white or grey) for top, face or side fixing. The idle end bracket has height adjustment. Self-lubricating bearing within the chain pull mechanism.

Extruded aluminium 45mm/50mm diameter anodised tube. Round 20mm/rectangular 35 x 10mm extruded aluminium hem bar available in polyester powder coated finish to RAL.../welded pocket hem bar.

Perlon side cable guides/20 x 20mm aluminium "C" side guide in PPC

Chain retaining pulley.

Dimensions: As shown on drawings.

Fixing: To subcontractors details.

Accessories: Extruded aluminium clip-on fascias

Fabrics: Fabric to be selected from Levolux

..... range
..... colour

In line with the policy of continuous product development Levolux reserves the right to alter specifications without prior notice.

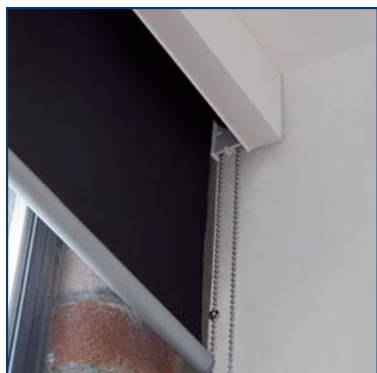

For further information on Levolux sunscreening systems and effective ways to control light, heat and glare please contact:

Levolux Limited
Forward Drive, Harrow,
Middlesex HA3 8NT.
United Kingdom
Telephone: (+44) 020 8863 9111
Facsimile: (+44) 020 8863 8760
www.levolux.com
info@levolux.com



Levolux A.T. Limited
24 Eastville Close, Eastern Avenue,
Gloucester GL4 3SJ
United Kingdom
Telephone: (+44) 01452 500007
Facsimile: (+44) 01452 527496
www.levolux.com
info@levolux.com